

- Cilindri compatti con interasse ISO 15552 o UNITOP
Fixing dimensions are compliant to norm ISO 15552 or UNITOP
- Predisposti per i fissaggi normalizzati
To be installed with standard fixing elements
- Grande affidabilità e lunga durata
High reliability and long life time
- Versione magnetica standard
Standard magnetic version
- Esecuzioni e corse speciali a richiesta
Special versions and strokes on request

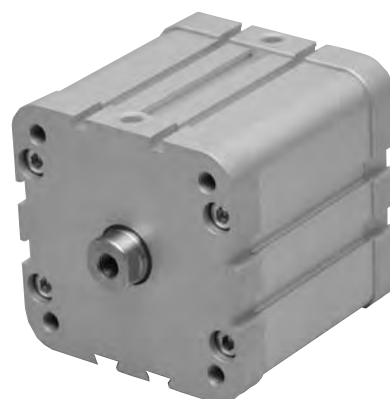

Materiali

Camicia: alluminio

Stelo: C45 cromato o INOX AISI 304

Testate: alluminio

Pistone: tecnopolimero (standard) o alluminio (su richiesta). Il pistone in tecnopolimero non è adatto per la versione ATEX.

Guarnizioni: poliuretano o VITON

Guarnizione stelo: poliuretano o VITON

Magnete: plastroferrite (non adatto per temperature oltre +60°C)

Materials

Barrel: aluminium

Piston-rod: C45 (chromium plated) or stainless steel

End-cups: aluminium

Piston: technopolymer (standard) or aluminium (on request). The piston in technopolymer is not suitable for ATEX.

Sealings: polyurethane or VITON

Piston-rod sealing: polyurethane or VITON

Magnet: magnetic iron compound (not suitable for temperatures over +60°C)

Pressione di esercizio <i>Working pressure</i>	max 10 bar max 1 MPa
Temperatura di esercizio <i>Temperature range</i>	standard (poliuretano/NBR): max +60°C VITON: max +110°C
Alesaggi <i>Bores</i>	32; 40; 50; 63; 80; 100 mm
Tipo di costruzione <i>Construction type</i>	Profilo quadro con cava centrale e cave laterali <i>Square aluminium profile</i>
Corse <i>Strokes</i>	5 ... 200 mm
Fluido <i>Fluid</i>	Aria filtrata 50µ con o senza lubrificazione <i>50µ filtered, lubricated or non lubricated air</i>

chiave di codifica

key to codes

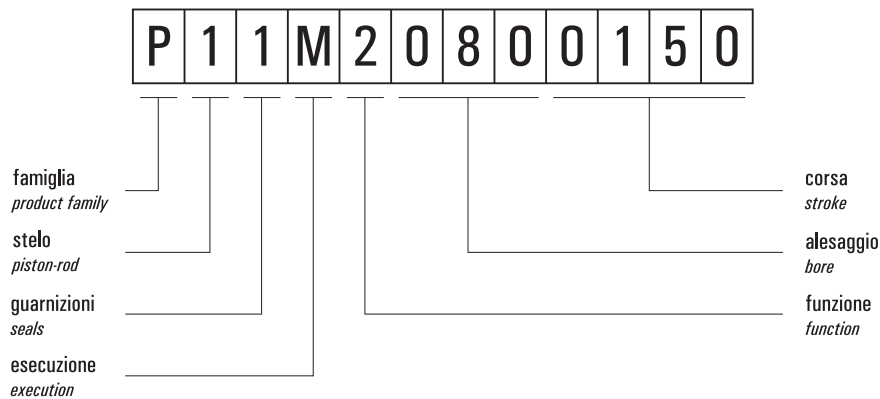

Famiglia [product family]

P cilindri compatti interasse ISO 15552
[compact cylinders with fixing distances ISO 15552]

R cilindri compatti interasse UNITOP
[compact cylinders with fixing distances UNITOP]

Stelo [piston-rod]

1 C45 cromato - filetto stelo femmina
[C45 chromium plated - female rod thread]

2 INOX - filetto stelo femmina
[stainless steel - female rod thread]

3 C45 cromato - filetto stelo maschio
[C45 chromium plated - male rod thread]

4 INOX - filetto stelo maschio
[stainless steel - male rod thread]

Guarnizioni [seals]

1 poliuretano *[polyurethane]*

2 tutte le guarnizioni in VITON *[all seals in VITON]*

3 guarnizioni dello stelo in VITON *[rod seals in VITON]*

Esecuzione [execution]

M magnetico *[magnetic]*

Funzione [function]

1 semplice effetto non ammortizzato molla anteriore
[single acting front spring without pneumatic cushioning]

2 doppio effetto non ammortizzato
[double acting without pneumatic cushioning]

3 semplice effetto non ammortizzato molla posteriore
[single acting back spring without pneumatic cushioning]

4 doppio effetto non ammortizzato stelo passante
[double acting without pneumatic cushioning, with passing-through rod]

versioni disponibili

available versions

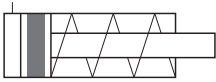
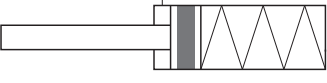
semplice effetto molla anteriore <i>single acting front spring</i> magnetico <i>magnetic</i> non ammortizzato <i>without pneumatic cushioning</i>	alesaggio		32	40	50	63	80	100	OPZIONI <i>options</i> Lo standard è evidenziato in grigio <i>The standard is marked with grey background</i>								
	corsa	bore								stroke							
	5		X	X	X	X	X	X		materiale stelo [piston-rod material] <table border="1"> <tr> <td>C45 cromato <i>C45 chromium plated</i></td> <td>INOX <i>stainless steel</i></td> </tr> </table> materiale guarnizioni [seals material] <table border="1"> <tr> <td>poliuret.</td> <td>tutte in VITON <i>all seals in VITON</i></td> <td>guarnizioni stelo in VITON <i>rod seals in VITON</i></td> </tr> </table> filetto stelo [rod thread] <table border="1"> <tr> <td>filetto stelo femmina <i>female rod thread</i></td> <td>filetto stelo maschio <i>male rod thread</i></td> </tr> </table>	C45 cromato <i>C45 chromium plated</i>	INOX <i>stainless steel</i>	poliuret.	tutte in VITON <i>all seals in VITON</i>	guarnizioni stelo in VITON <i>rod seals in VITON</i>	filetto stelo femmina <i>female rod thread</i>	filetto stelo maschio <i>male rod thread</i>
	C45 cromato <i>C45 chromium plated</i>	INOX <i>stainless steel</i>															
	poliuret.	tutte in VITON <i>all seals in VITON</i>	guarnizioni stelo in VITON <i>rod seals in VITON</i>														
	filetto stelo femmina <i>female rod thread</i>	filetto stelo maschio <i>male rod thread</i>															
	10		X	X	X	X	X	X									
	25		X	X	X	X	X	X									
	30				X	X	X	X									
	40																
	50																
	75																
	80																
	100																
	125																
150																	
160																	
200																	
semplice eff. molla posteriore <i>single acting back spring</i> magnetico <i>magnetic</i> non ammortizzato <i>without pneumatic cushioning</i>	alesaggio		32	40	50	63	80	100	OPZIONI <i>options</i> Lo standard è evidenziato in grigio <i>The standard is marked with grey background</i>								
corsa	bore	stroke															
	5		X	X	X	X	X	X		materiale stelo [piston-rod material] <table border="1"> <tr> <td>C45 cromato <i>C45 chromium plated</i></td> <td>INOX <i>stainless steel</i></td> </tr> </table> materiale guarnizioni [seals material] <table border="1"> <tr> <td>poliuret.</td> <td>tutte in VITON <i>all seals in VITON</i></td> <td>guarnizioni stelo in VITON <i>rod seals in VITON</i></td> </tr> </table> filetto stelo [rod thread] <table border="1"> <tr> <td>filetto stelo femmina <i>female rod thread</i></td> <td>filetto stelo maschio <i>male rod thread</i></td> </tr> </table>	C45 cromato <i>C45 chromium plated</i>	INOX <i>stainless steel</i>	poliuret.	tutte in VITON <i>all seals in VITON</i>	guarnizioni stelo in VITON <i>rod seals in VITON</i>	filetto stelo femmina <i>female rod thread</i>	filetto stelo maschio <i>male rod thread</i>
	C45 cromato <i>C45 chromium plated</i>	INOX <i>stainless steel</i>															
	poliuret.	tutte in VITON <i>all seals in VITON</i>	guarnizioni stelo in VITON <i>rod seals in VITON</i>														
	filetto stelo femmina <i>female rod thread</i>	filetto stelo maschio <i>male rod thread</i>															
	10		X	X	X	X	X	X									
	25		X	X	X	X	X	X									
	30				X	X	X	X									
	40																
	50																
	75																
	80																
	100																
	125																
150																	
160																	
200																	

versioni disponibili

available versions

doppio effetto <i>double acting</i> magnetico <i>magnetic</i> non ammortizzato <i>without pneumatic cushioning</i>	alesaggio		32	40	50	63	80	100	OPZIONI <i>options</i> Lo standard è evidenziato in grigio <i>The standard is marked with grey background</i>							
	corsa	bore														
	5	stroke	X	X	X	X	X	X	materiale stelo [piston-rod material] <table border="1"> <tr> <td>C45 cromato <i>C45 chromium plated</i></td> <td>INOX <i>stainless steel</i></td> </tr> </table> materiale guarnizioni [seals material] <table border="1"> <tr> <td>poliuret.</td> <td>tutte in VITON <i>all seals in VITON</i></td> <td>guarnizioni stelo in VITON <i>rod seals in VITON</i></td> </tr> </table> filetto stelo [rod thread] <table border="1"> <tr> <td>filetto stelo femmina <i>female rod thread</i></td> <td>filetto stelo maschio <i>male rod thread</i></td> </tr> </table>	C45 cromato <i>C45 chromium plated</i>	INOX <i>stainless steel</i>	poliuret.	tutte in VITON <i>all seals in VITON</i>	guarnizioni stelo in VITON <i>rod seals in VITON</i>	filetto stelo femmina <i>female rod thread</i>	filetto stelo maschio <i>male rod thread</i>
	C45 cromato <i>C45 chromium plated</i>	INOX <i>stainless steel</i>														
	poliuret.	tutte in VITON <i>all seals in VITON</i>	guarnizioni stelo in VITON <i>rod seals in VITON</i>													
	filetto stelo femmina <i>female rod thread</i>	filetto stelo maschio <i>male rod thread</i>														
	10	X	X	X	X	X	X	X								
	25	X	X	X	X	X	X	X								
	30	X	X	X	X	X	X	X								
	40	X	X	X	X	X	X	X								
	50	X	X	X	X	X	X	X								
	75	X	X	X	X	X	X	X								
	80	X	X	X	X	X	X	X								
	100	X	X	X	X	X	X	X								
	125	X	X	X	X	X	X	X								
	150	X	X	X	X	X	X	X								
160	X	X	X	X	X	X	X									
200	X	X	X	X	X	X	X									
doppio effetto <i>double acting</i> magnetico <i>magnetic</i> non ammortizzato <i>without pneumatic cushioning</i> stelo passante <i>passing-through rod</i>	alesaggio		32	40	50	63	80	100	OPZIONI <i>options</i> Lo standard è evidenziato in grigio <i>The standard is marked with grey background</i>							
	corsa	bore														
	5	stroke	X	X	X	X	X	X	materiale stelo [piston-rod material] <table border="1"> <tr> <td>C45 cromato <i>C45 chromium plated</i></td> <td>INOX <i>stainless steel</i></td> </tr> </table> materiale guarnizioni [seals material] <table border="1"> <tr> <td>poliuret.</td> <td>tutte in VITON <i>all seals in VITON</i></td> <td>guarnizioni stelo in VITON <i>rod seals in VITON</i></td> </tr> </table> filetto stelo [rod thread] <table border="1"> <tr> <td>filetto stelo femmina <i>female rod thread</i></td> <td>filetto stelo maschio <i>male rod thread</i></td> </tr> </table>	C45 cromato <i>C45 chromium plated</i>	INOX <i>stainless steel</i>	poliuret.	tutte in VITON <i>all seals in VITON</i>	guarnizioni stelo in VITON <i>rod seals in VITON</i>	filetto stelo femmina <i>female rod thread</i>	filetto stelo maschio <i>male rod thread</i>
	C45 cromato <i>C45 chromium plated</i>	INOX <i>stainless steel</i>														
	poliuret.	tutte in VITON <i>all seals in VITON</i>	guarnizioni stelo in VITON <i>rod seals in VITON</i>													
	filetto stelo femmina <i>female rod thread</i>	filetto stelo maschio <i>male rod thread</i>														
	10	X	X	X	X	X	X	X								
	25	X	X	X	X	X	X	X								
	30	X	X	X	X	X	X	X								
	40	X	X	X	X	X	X	X								
	50	X	X	X	X	X	X	X								
	75	X	X	X	X	X	X	X								
	80	X	X	X	X	X	X	X								
	100	X	X	X	X	X	X	X								
	125	X	X	X	X	X	X	X								
	150	X	X	X	X	X	X	X								
160	X	X	X	X	X	X	X									
200	X	X	X	X	X	X	X									

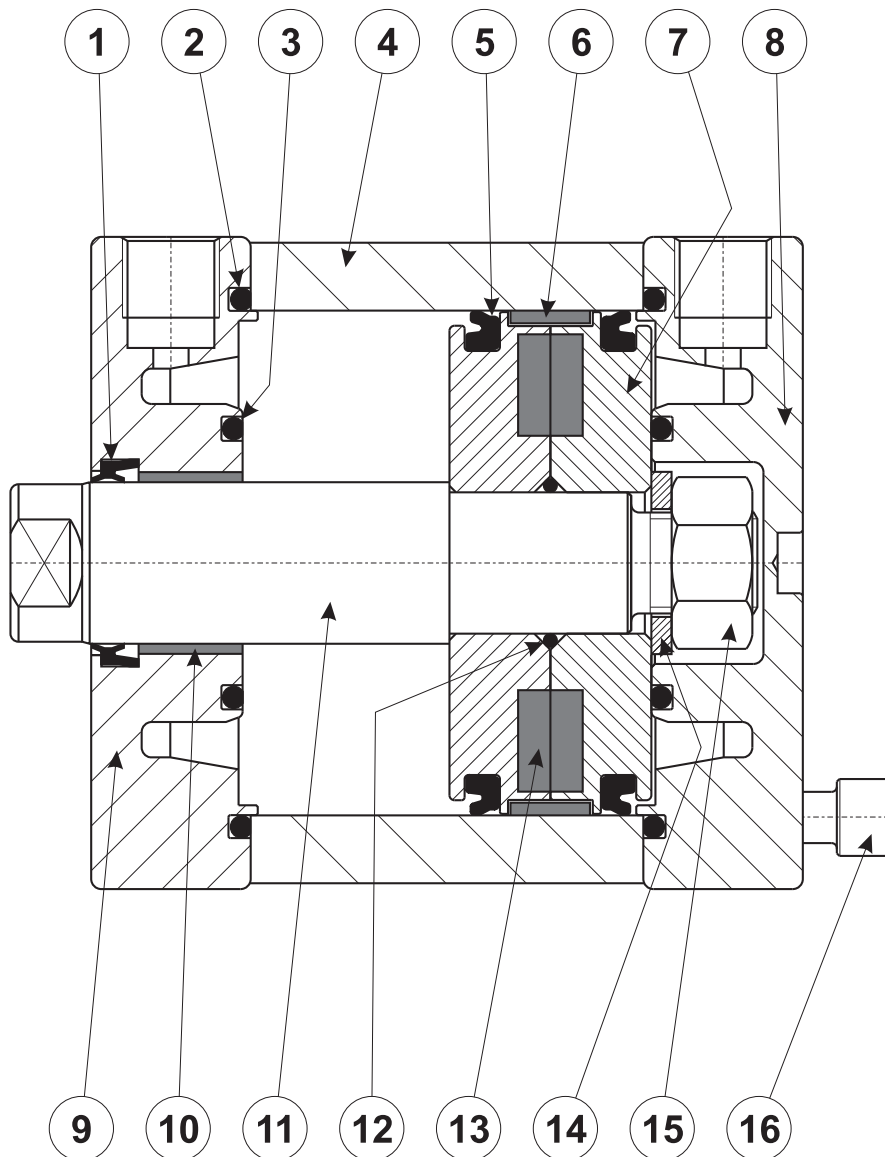

1. Guarnizione stelo: poliuretano o VITON
2. O-Ring per tenuta testata: NBR o VITON
3. O-Ring paracolpi: NBR o VITON
4. Camicia: alluminio profilato, calibrato e anodizzato
5. Guarnizione a labbro per pistone: poliuretano o VITON
6. Anello guida per pistone: bronzo PTFE (solo per pistone in alluminio)
7. Pistone: tecnopolimero o alluminio
8. Testata posteriore: alluminio
9. Testata anteriore: alluminio
10. Boccola guida: materiale autolubrificante
11. Stelo: acciaio C45 cromato o INOX AISI 304
12. O-Ring per tenuta pistone: NBR o VITON
13. Magnete: plastoferrite
14. Rondella piana
15. Dado per bloccaggio stelo
16. Vite per fissaggio testata

kit guarnizioni di ricambio

seals kit

MAGNETICO, guarnizioni standard					
normale			stelo passante [passing-through rod]		
per alesaggio for bore	sigla part number	codice code	per alesaggio for bore	sigla part number	codice code
32	GP032	25.103.2	32	GP032P	25.113.2
40	GP040	25.104.2	40	GP040P	25.114.2
50	GP050	25.105.2	50	GP050P	25.115.2
63	GP063	25.106.2	63	GP063P	25.116.2
80	GP080	25.107.2	80	GP080P	25.117.2
100	GP100	25.108.2	100	GP100P	25.118.2
MAGNETICO, guarnizioni VITON					
normale			stelo passante [passing-through rod]		
per alesaggio for bore	sigla part number	codice code	per alesaggio for bore	sigla part number	codice code
32	GP032V	25.123.2	32	GP032PV	25.133.2
40	GP040V	25.124.2	40	GP040PV	25.134.2
50	GP050V	25.125.2	50	GP050PV	25.135.2
63	GP063V	25.126.2	63	GP063PV	25.136.2
80	GP080V	25.127.2	80	GP080PV	25.137.2
100	GP100V	25.128.2	100	GP100PV	25.138.2

VERSIONE MAGNETICA, FILETTO STELO FEMMINA
magnetic version, female rod thread

alesaggio 32
bore 32

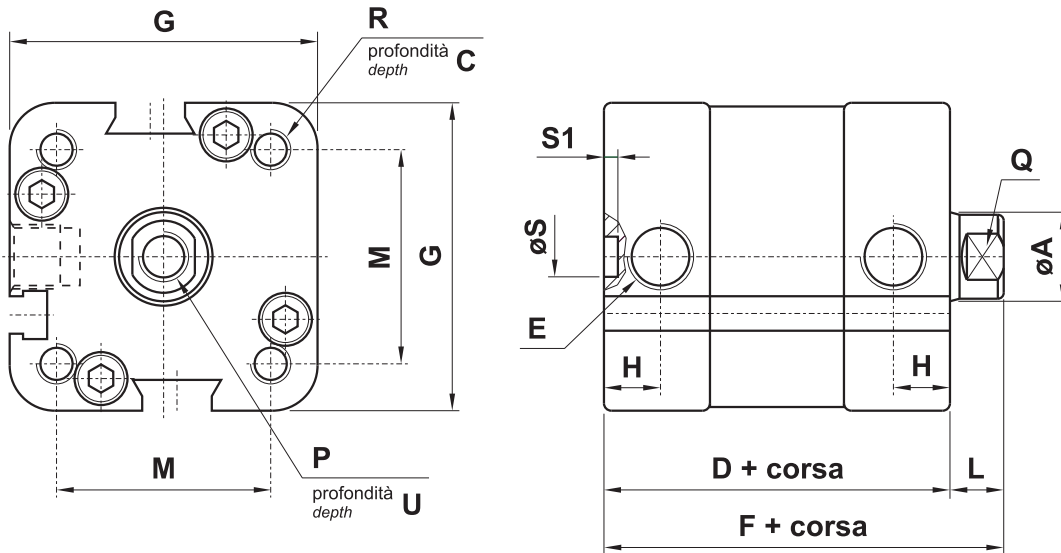

ø	A	C	D	E	F*	G		H	L*	M		P	Q	R		S	S1	U
						ISO	UNITOP			ISO	UNITOP			ISO	UNITOP			
32	12	14	46	G1/8"	53	46	46	7	7	32.3	32.3	M8	ch 10	M6	M6	6	2.5	13.5

alesaggio 40 - 50 - 63
bore 40 - 50 - 63

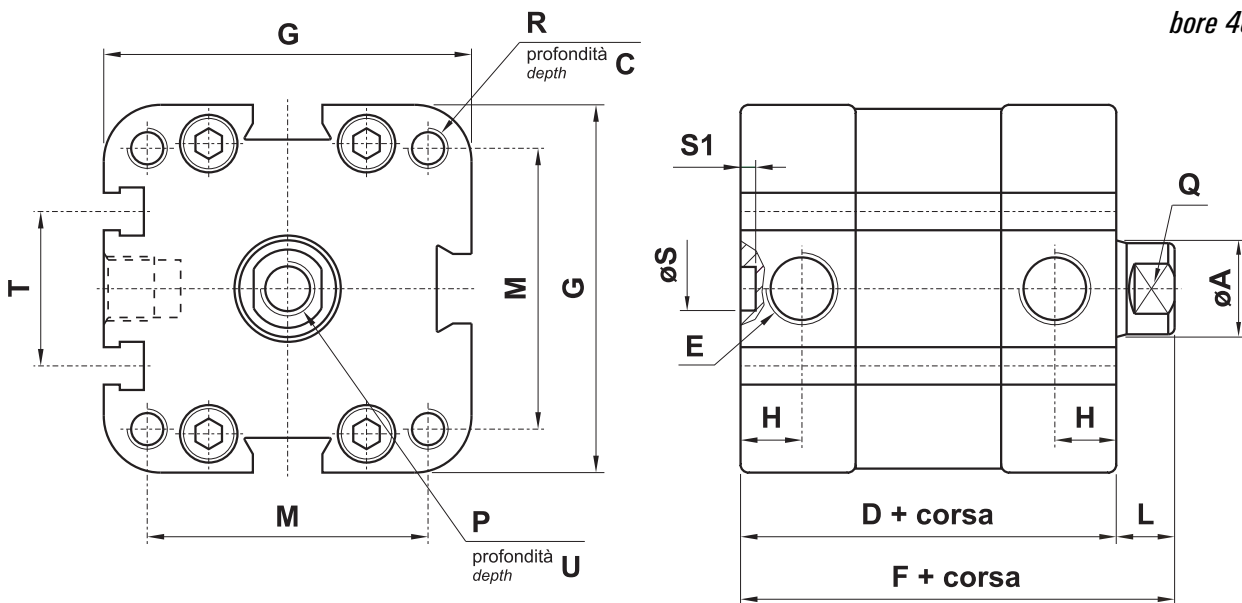

ø	A	C	D	E	F*	G		H	L*	M		P	Q	R		S	S1	T	U
						ISO	UNITOP			ISO	UNITOP			ISO	UNITOP				
40	12	14	46	G1/8"	53	55	55	6.5	7	38	42	M8	ch 10	M6	M6	6	2.5	22	13.5
50	16	16	50	G1/8"	58	64.5	64.5	8	8	46.5	50	M10	ch 13	M8	M8	6	2.5	24	16
63	16	16	53	G1/8"	61	78	78	8	8	56.5	62	M10	ch 13	M8	M10	6	2.5	29	16

cilindri compatti

compact cylinders



OBSOLETO
OBSOLETE

alesaggio 80 - 100

bore 80 - 100

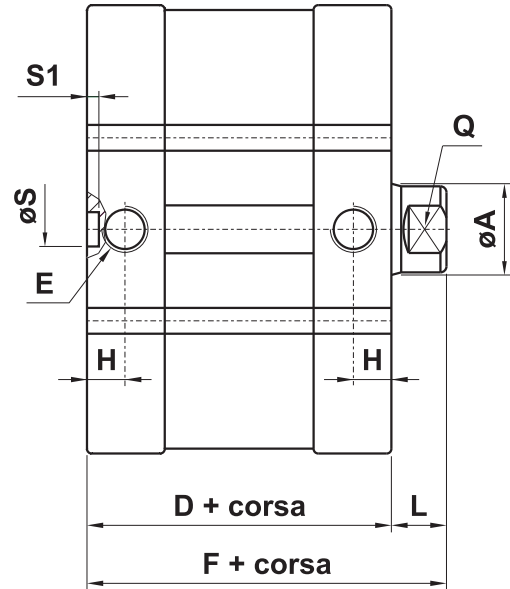
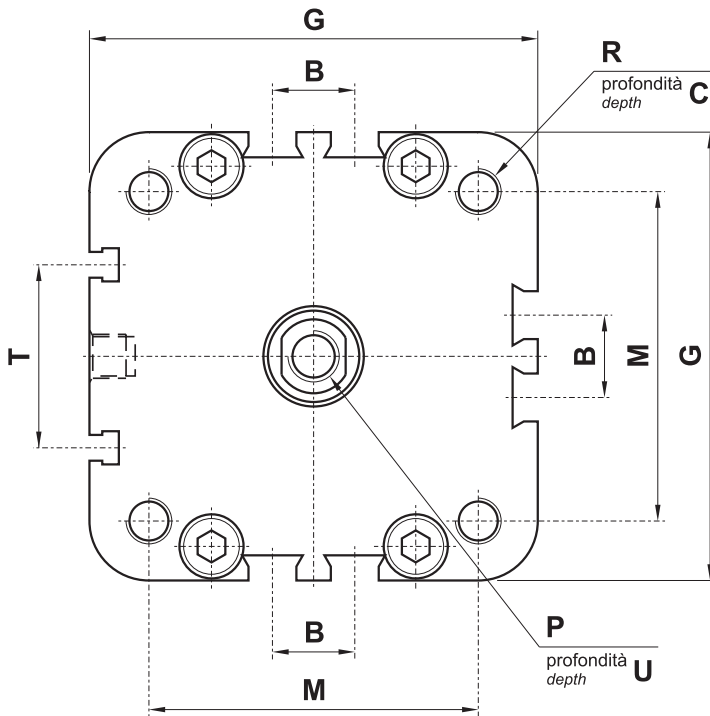

ø	A	B	C	D	E	F*	G		H	L*	M		P	Q	R		S	S1	T	U
							ISO	UNITOP			ISO	UNITOP			ISO	UNITOP				
80	20	18	17	56	G1/8"	66	99	99	8	10	72	82	M10	ch 17	M10	M10	8	4	40	20
100	25	28	17.5	67	G1/4"	77	119	119	9	10	89	103	M12	ch 22	M10	M10	8	4	40	24

F*, L*: In caso di cilindro semplice effetto molla posteriore aggiungere la lunghezza della corsa

F*, L*: In case of single acting cylinder with back spring add stroke length

OBSOLETO

VERSIONE MAGNETICA, FILETTO STELO FEMMINA, STELO PASSANTE
magnetic version, female rod thread, passing-through rod

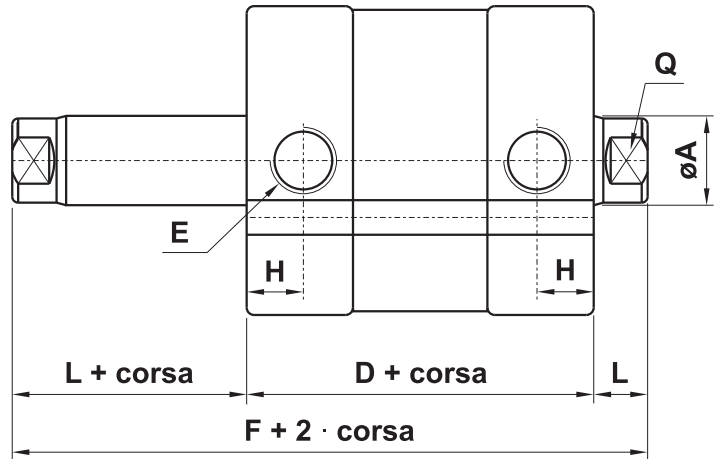
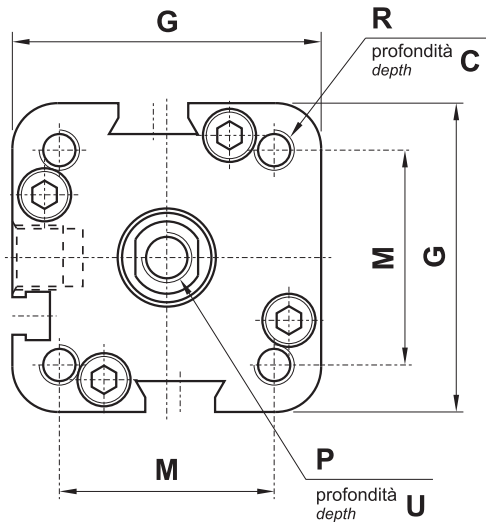

alesaggio 32
bore 32

ø	A	C	D	E	F	G		H	L	M		P	Q	R		U
						ISO	UNITOP			ISO	UNITOP			ISO	UNITOP	
32	12	14	46	G1/8"	60	46	46	7	7	32.3	32.3	M8	ch 10	M6	M6	13.5

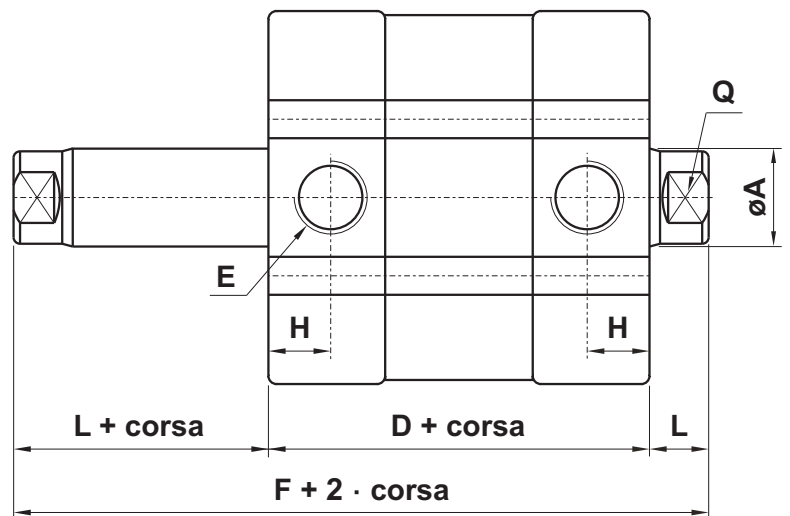
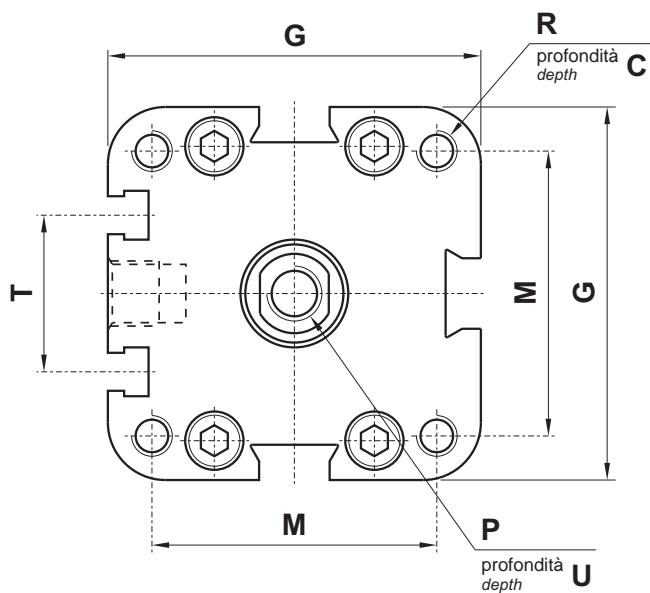

alesaggio 40 - 50 - 63
bore 40 - 50 - 63

ø	A	C	D	E	F	G		H	L	M		P	Q	R		T	U
						ISO	UNITOP			ISO	UNITOP			ISO	UNITOP		
40	12	14	46	G1/8"	60	55	55	6.5	7	38	42	M8	ch 10	M6	M6	22	13.5
50	16	16	50	G1/8"	66	64.5	64.5	8	8	46.5	50	M10	ch 13	M8	M8	24	16
63	16	16	53	G1/8"	69	78	78	8	8	56.5	62	M10	ch 13	M8	M10	29	16

cilindri compatti

compact cylinders



OBSOLETO
OBSOLETE

alesaggio 80 - 100

bore 80 - 100

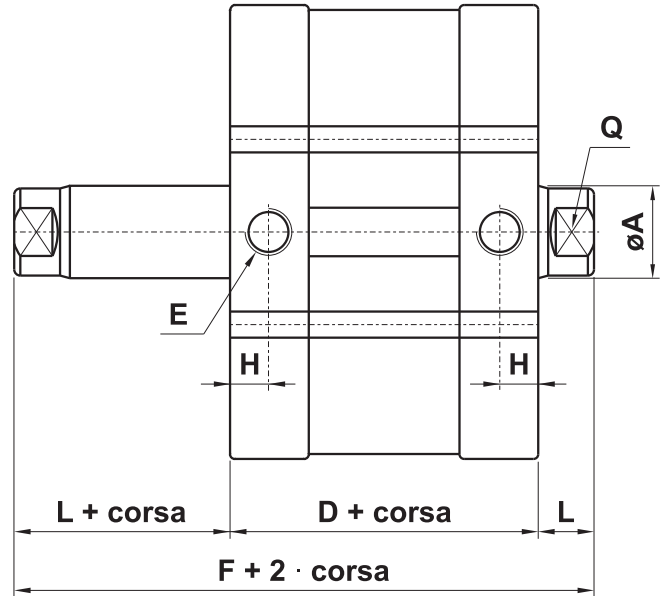
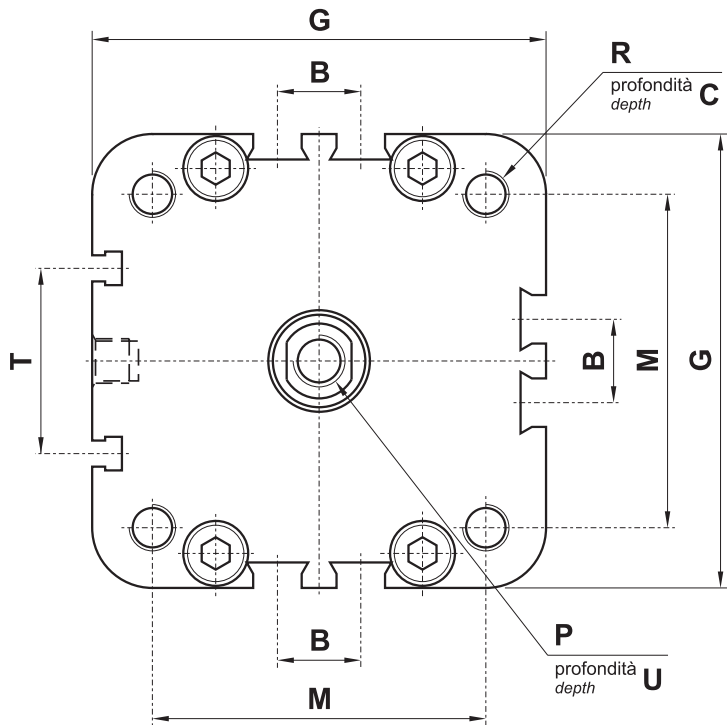

ø	A	B	C	D	E	F	G		H	L	M		P	Q	R		T	U
							ISO	UNITOP			ISO	UNITOP			ISO	UNITOP		
80	20	18	17	56	G1/8"	76	99	99	8	10	72	82	M10	ch 17	M10	M10	40	20
100	25	28	17.5	67	G1/4"	87	119	119	9	10	89	103	M12	ch 22	M10	M10	40	24

OBSOLETO

VERSIONE MAGNETICA, FILETTO STELO MASCHIO
magnetic version, male rod thread

alesaggio 32
bore 32

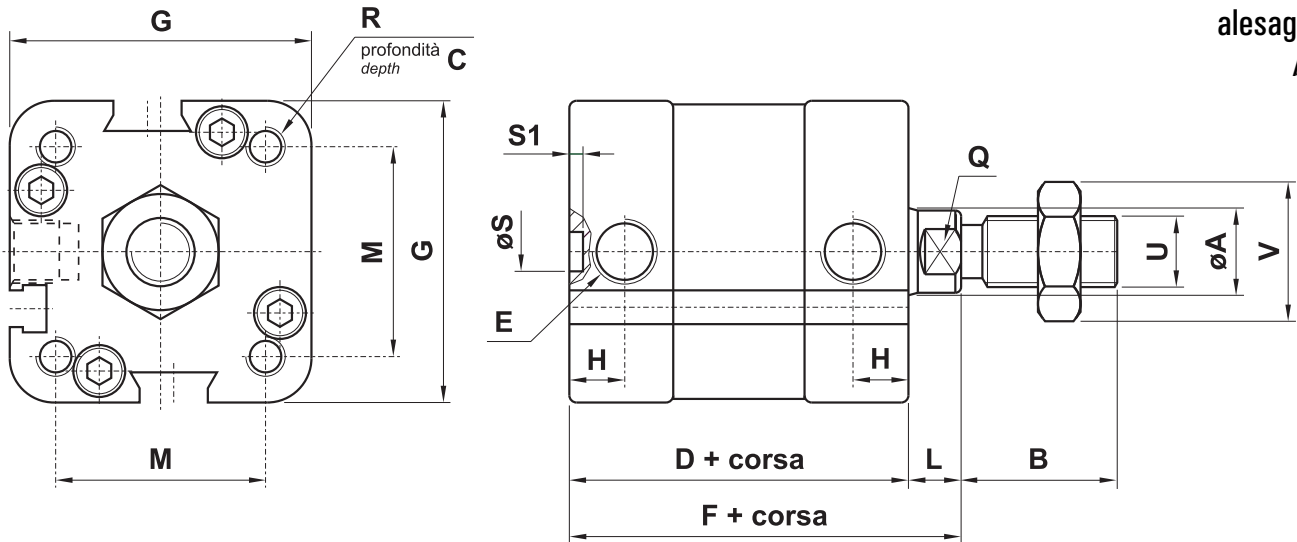

ø	A	B	C	D	E	F*	G		H	L*	M		Q	R		S	S1	U	V
							ISO	UNITOP			ISO	UNITOP		ISO	UNITOP				
32	12	22	14	46	G1/8"	53	46	46	7	7	32.3	32.3	ch 10	M6	M6	6	2.5	M10x1.25	ch 17

alesaggio 40 - 50 - 63
bore 40 - 50 - 63

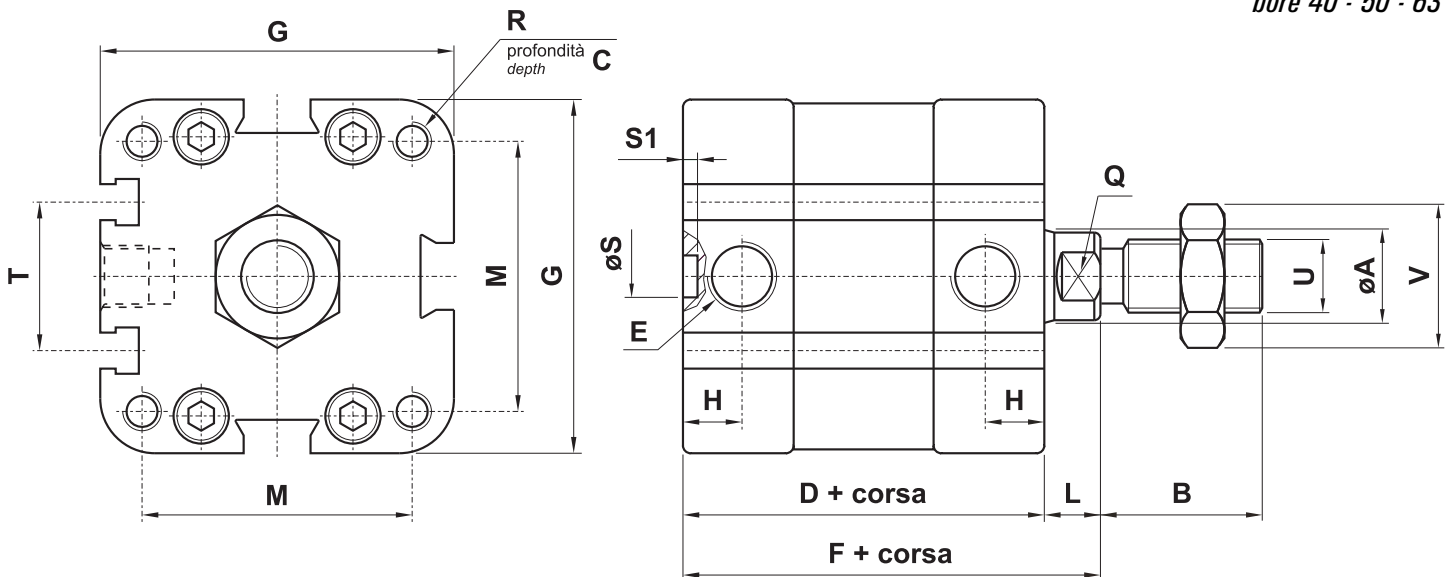

ø	A	B	C	D	E	F*	G		H	L*	M		Q	R		S	S1	T	U	V
							ISO	UNITOP			ISO	UNITOP		ISO	UNITOP					
40	12	22	14	46	G1/8"	53	55	55	6.5	7	38	42	ch 10	M6	M6	6	2.5	22	M10x1.25	ch 17
50	16	24	16	50	G1/8"	58	64.5	64.5	8	8	46.5	50	ch 13	M8	M8	6	2.5	24	M12x1.25	ch 19
63	16	24	16	53	G1/8"	61	78	78	8	8	56.5	62	ch 13	M8	M10	6	2.5	29	M12x1.25	ch 19

cilindri compatti

compact cylinders



OBSOLETO
OBSOLETE

alesaggio 80 - 100
bore 80 - 100

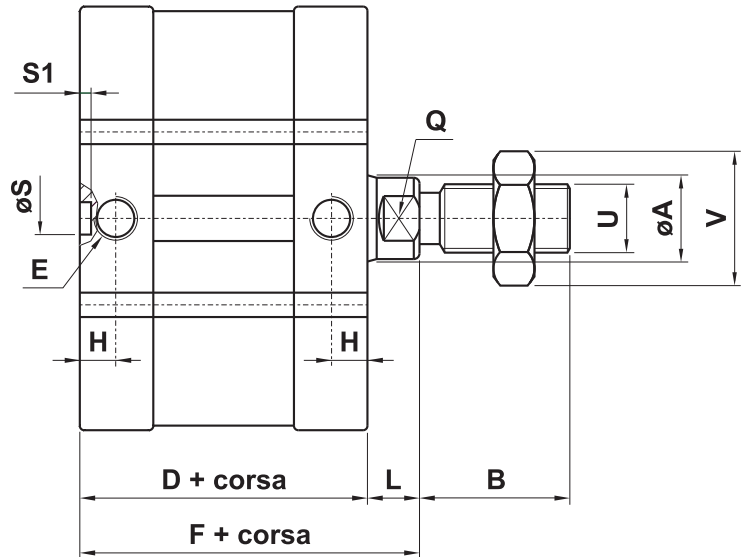
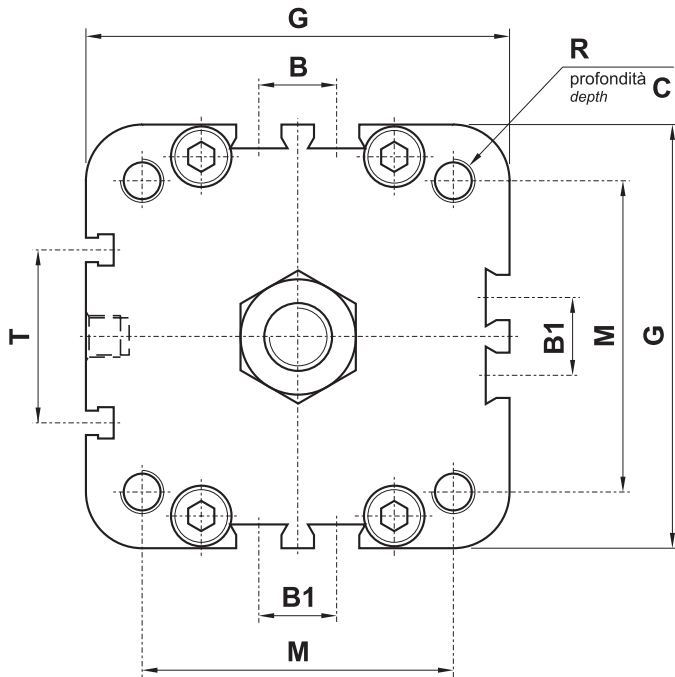

ø	A	B	B1	C	D	E	F*	G		H	L*	M		Q	R		S	S1	T	U	V
								ISO	UNITOP			ISO	UNITOP		ISO	UNITOP					
80	20	32	18	17	56	G1/8"	66	99	99	8	10	72	82	ch 17	M10	M10	8	4	40	M16x1.5	ch 24
100	25	40	28	17.5	67	G1/4"	77	119	119	9	10	89	103	ch 22	M10	M10	8	4	40	M20x1.5	ch 30

F*, L*: In caso di cilindro semplice effetto molla posteriore aggiungere la lunghezza della corsa

F*, L*: In case of single acting cylinder with back spring add stroke length

OBSOLETO

VERSIONE MAGNETICA, FILETTO STELO MASCHIO, STELO PASSANTE
magnetic version, male rod thread, passing-through rod

alesaggio 32
bore 32

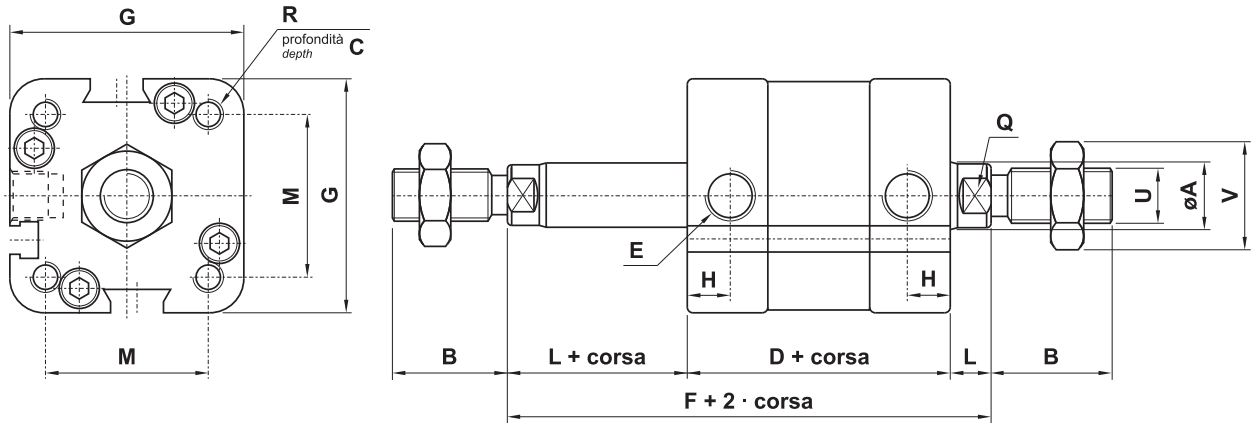

ø	A	B	C	D	E	F	G		H	L	M		Q	R		U	V
							ISO	UNITOP			ISO	UNITOP		ISO	UNITOP		
32	12	22	14	46	G1/8"	60	46	46	7	7	32.3	32.3	ch 10	M6	M6	M10x1.25	ch 17

alesaggio 40 - 50 - 63
bore 40 - 50 - 63

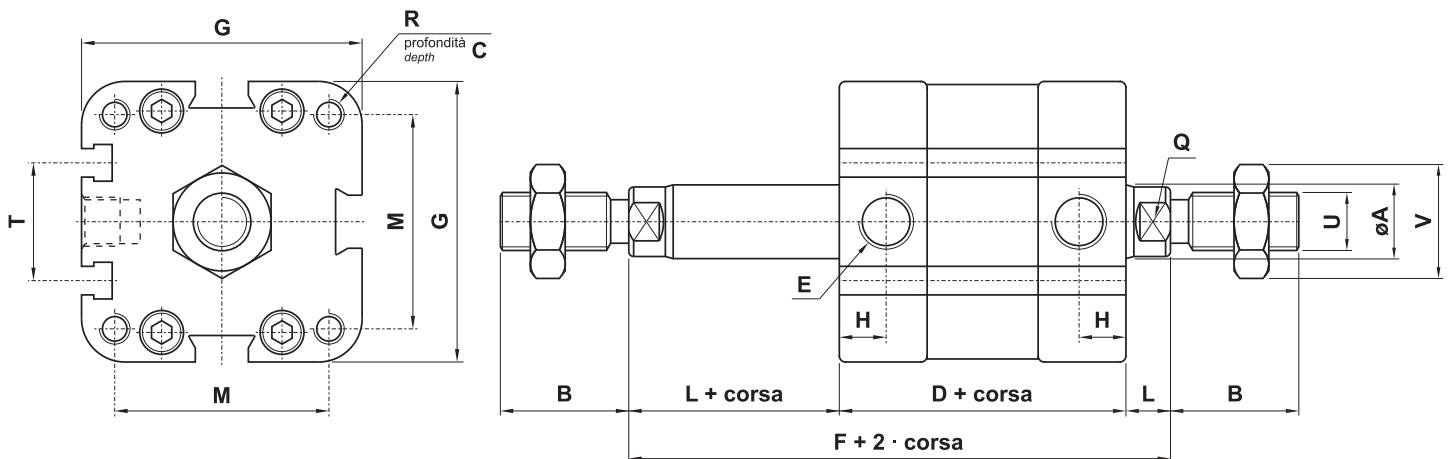

ø	A	B	C	D	E	F	G		H	L	M		Q	R		T	U	V
							ISO	UNITOP			ISO	UNITOP		ISO	UNITOP			
40	12	22	14	46	G1/8"	60	55	55	6.5	7	38	42	ch 10	M6	M6	22	M10x1.25	ch 17
50	16	24	16	50	G1/8"	66	64.5	64.5	8	8	46.5	50	ch 13	M8	M8	24	M12x1.25	ch 19
63	16	24	16	53	G1/8"	69	78	78	8	8	56.5	62	ch 13	M8	M10	29	M12x1.25	ch 19

cilindri compatti

compact cylinders



OBSOLETO
OBSOLETE

alesaggio 80 - 100
bore 80 - 100

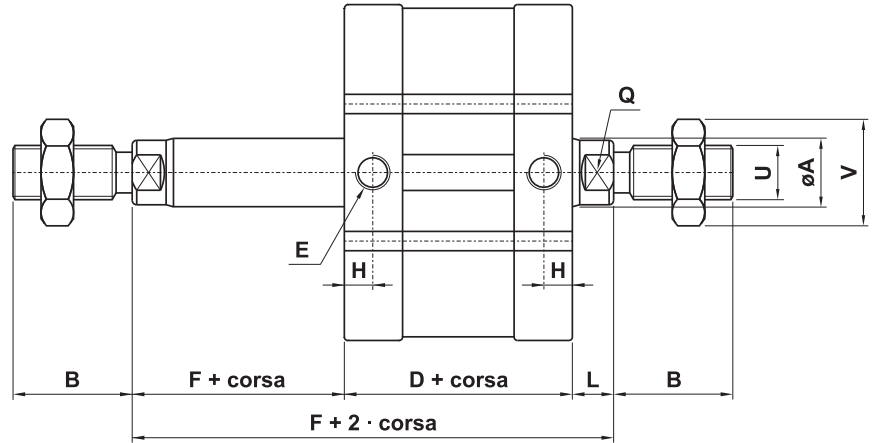
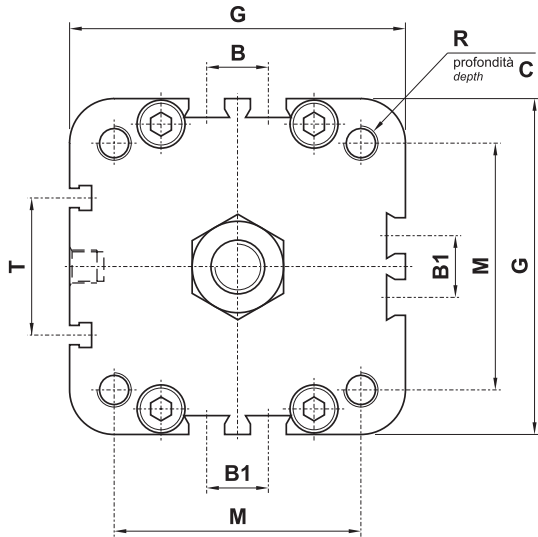

ø	A	B	B1	C	D	E	F	G		H	L	M		Q	R		T	U	V
								ISO	UNITOP			ISO	UNITOP		ISO	UNITOP			
80	20	32	18	17	56	G1/8"	76	99	99	8	10	72	82	ch 17	M10	M10	40	M16x1.5	ch 24
100	25	40	28	17.5	67	G1/4"	87	119	119	9	10	89	103	ch 22	M10	M10	40	M20x1.5	ch 30

OBSOLETO

flangia intermedia per cilindri compatti contrapposti

intermediate flange for opposite compact cylinders

Questa flangia intermedia deve essere inserita tra due cilindri compatti per formare un cilindro contrapposto. È venduta in kit con tutti i particolari necessari al suo assemblaggio.

This intermediate flange is inserted between two compact cylinders to form an opposite cylinder. It is sold in kit with all necessary pieces for installation.

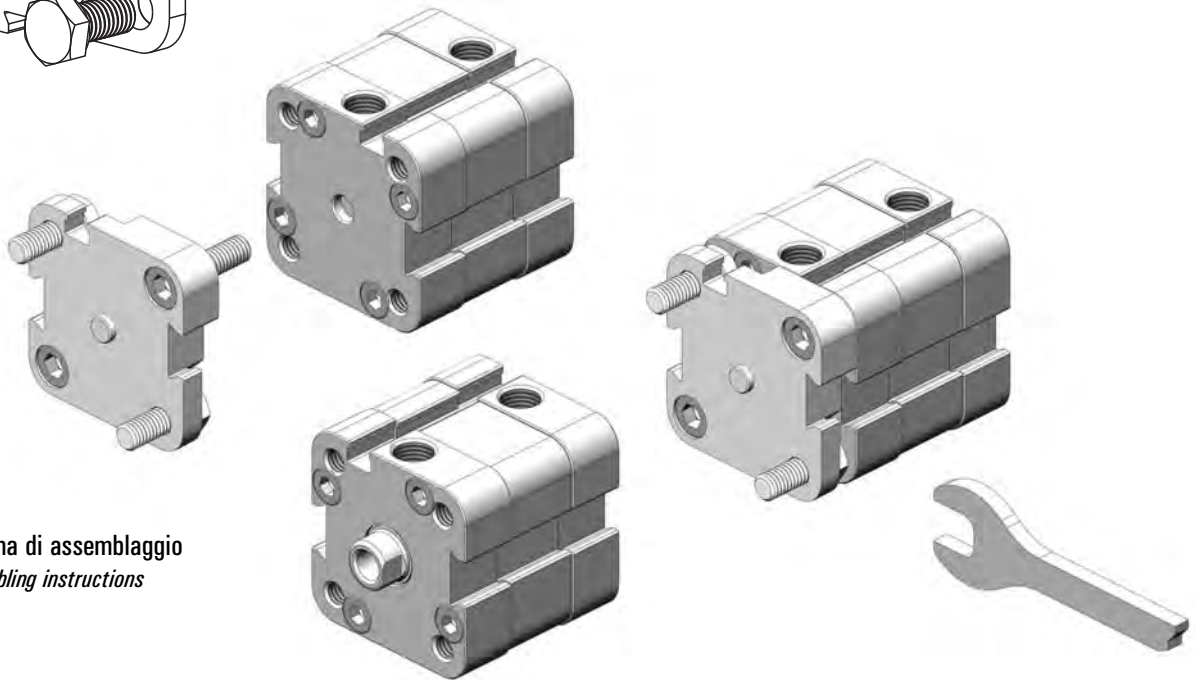
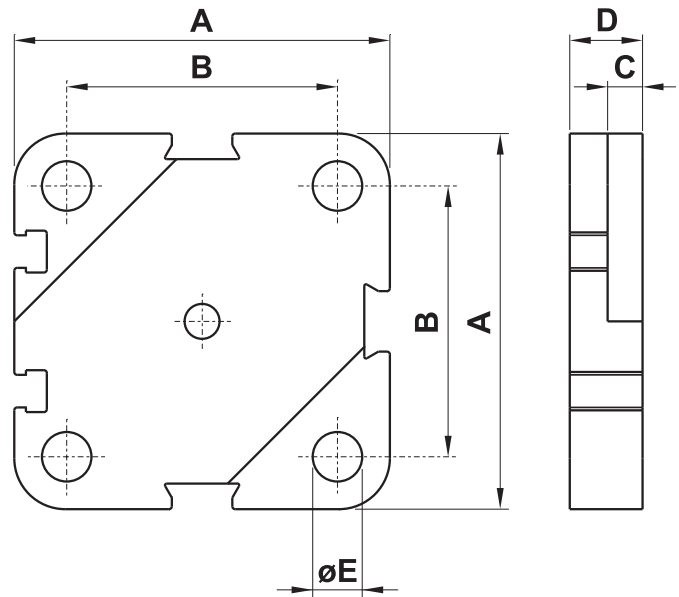
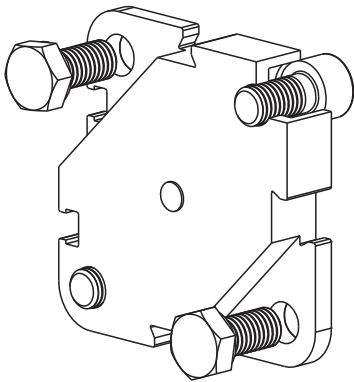

Schema di assemblaggio
Assembling instructions

codice code		per alesaggio for bore	A	B		C	D	E
ISO	UNITOP			ISO	UNITOP			
25.082.2	25.082.2	32	46	32.3	32.3	5	10.5	6.5
25.083.2	25.088.2	40	55	38	42	6	12.5	6.5
25.084.2	25.089.2	50	64.5	46.5	50	6	12.5	8.5
25.085.2	25.090.2	63	78	56.5	62	7	13.5	8.5
25.086.2	25.091.2	80	98	72	82	7	15	10.5
25.087.2	25.092.2	100	119	89	103	7	15	10.5

kit cilindro compatto

compact cylinder kit

Il kit comprende:

- testate premontate
- pistone con magnete, guarnizioni e anello di guida (per pistone in alluminio)
- viti
- tutte le guarnizioni necessarie

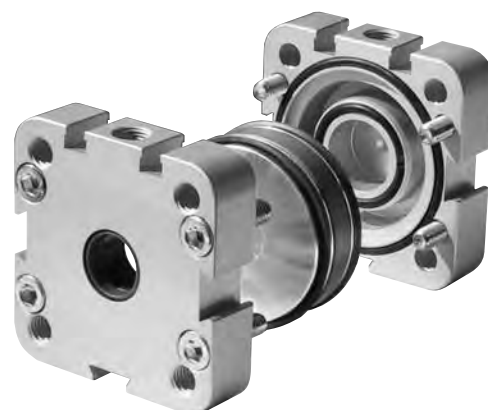

MAGNETICO, guarnizioni standard

normale					stelo passante [passing-through rod]				
per alesaggio for bore	ISO		UNITOP		per alesaggio for bore	ISO		UNITOP	
	sigla part number	codice code	sigla part number	codice code		sigla part number	codice code	sigla part number	codice code
32	KP032	25.004.3	KR032	25.104.3	32	KP032P	25.014.3	KR032P	25.114.3
40	KP040	25.005.3	KR040	25.105.3	40	KP040P	25.015.3	KR040P	25.115.3
50	KP050	25.006.3	KR050	25.106.3	50	KP050P	25.016.3	KR050P	25.116.3
63	KP063	25.007.3	KR063	25.107.3	63	KP063P	25.017.3	KR063P	25.117.3
80	KP080	25.008.3	KR080	25.108.3	80	KP080P	25.018.3	KR080P	25.118.3
100	KP100	25.009.3	KR100	25.109.3	100	KP100P	25.019.3	KR100P	25.119.3

MAGNETICO, guarnizioni VITON

normale					stelo passante [passing-through rod]				
per alesaggio for bore	ISO		UNITOP		per alesaggio for bore	ISO		UNITOP	
	sigla part number	codice code	sigla part number	codice code		sigla part number	codice code	sigla part number	codice code
32	KP032V	25.024.3	KR032V	25.124.3	32	KP032PV	25.034.3	KR032PV	25.134.3
40	KP040V	25.025.3	KR040V	25.125.3	40	KP040PV	25.035.3	KR040PV	25.135.3
50	KP050V	25.026.3	KR050V	25.126.3	50	KP050PV	25.036.3	KR050PV	25.136.3
63	KP063V	25.027.3	KR063V	25.127.3	63	KP063PV	25.037.3	KR063PV	25.137.3
80	KP080V	25.028.3	KR080V	25.128.3	80	KP080PV	25.038.3	KR080PV	25.138.3
100	KP100V	25.029.3	KR100V	25.129.3	100	KP100PV	25.039.3	KR100PV	25.139.3

Maggiori informazioni sono disponibili all'indirizzo internet <http://www.azpneumatica.srl/azweb/ita/kitcilc.htm>

More information is available at the internet address <http://www.azpneumatica.srl/azweb/ita/kitcilc.htm>

barre per camicia cilindri compatti

barrel for compact cylinders

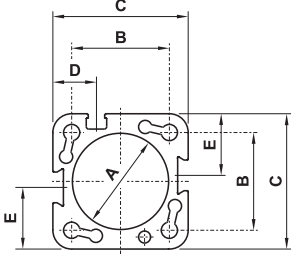
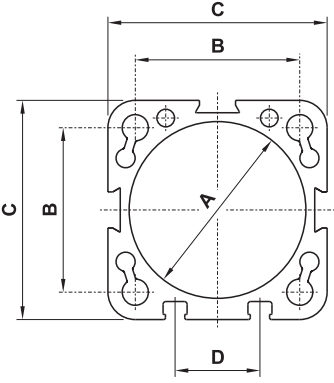
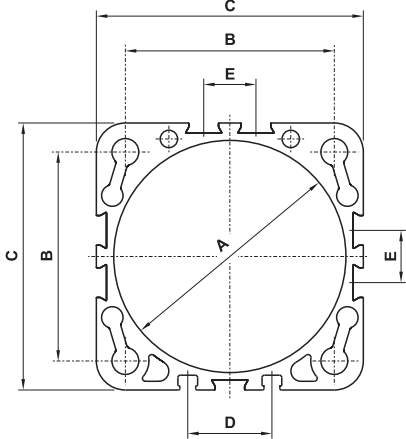

OBSOLETO
OBSOLETE

	codice di ordinazione order code	dimensioni - dimensions [mm]					peso weight [kg/m]
		A	B	C	D	E	
	000.523.7	$\varnothing 32^{+0.16}$	32.5	45	14.5	20.5	-
	000.524.7	$\varnothing 40^{+0.16}$	38	53	22	-	-
	000.525.7	$\varnothing 50^{+0.19}$	46.5	63	24	-	-
	000.526.7	$\varnothing 63^{+0.19}$	56.5	76.5	29	-	-
	000.527.7	$\varnothing 80^{+0.22}$	72	95	40	18	-
	000.528.7	$\varnothing 100^{+0.45}$	89	115	40	28	-

composizione chimica chemical composition	Cu	Fe	Mn	Mg	Si	Zn	Cr	Ti	Al resto
	≤ 0.10	0.10 ÷ 0.30	≤ 0.10	0.35 ÷ 0.60	0.30 ÷ 0.60	≤ 0.15	≤ 0.05	≤ 0.10	

Fori di fissaggio

dal $\varnothing 32$ al $\varnothing 100$: predisposti per la filettatura metrica mediante rullatura

Fixing holes

from $\varnothing 32$ to $\varnothing 100$: prepared for metric thread through rolling

OBSOLETO

fissaggi per cilindri compatti ISO

fixing elements for ISO compact cylinders



OBSOLETO
OBSOLETE

Per altre informazioni vedi le pagine 538-544 (fissaggi per cilindri ISO 15552)

For more information refer to pages 538-544 (fixing elements for cylinders ISO 15552)

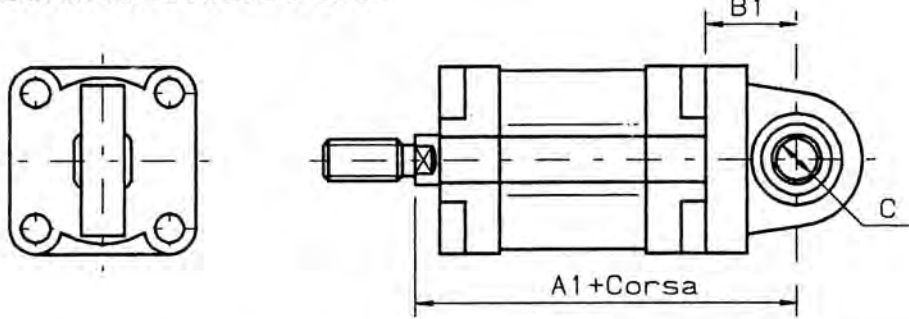
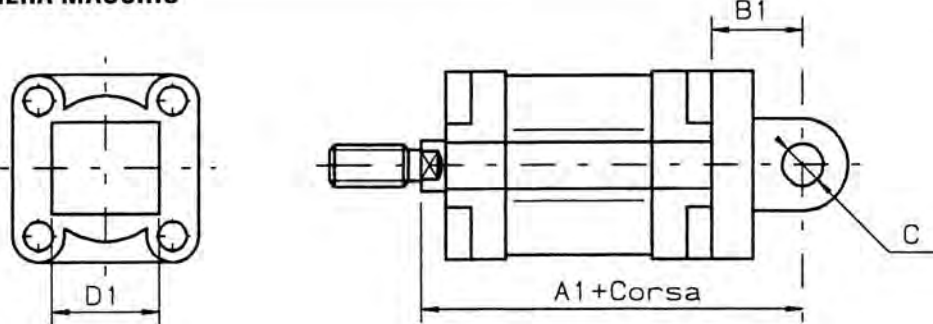
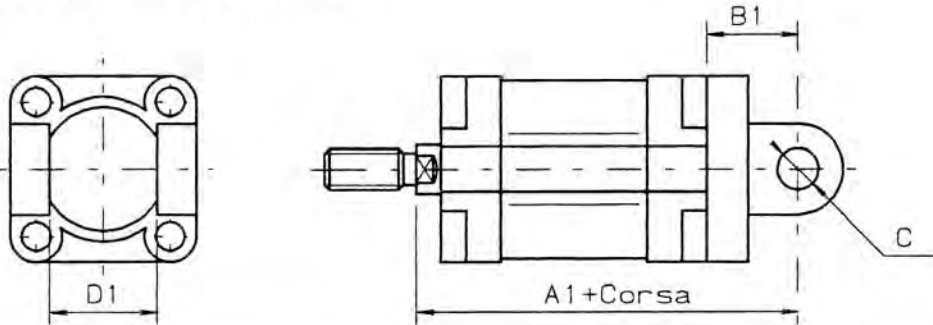
<p>CERNIERA MASCHIO SNODO SFERICO</p> 	<p>CMSS...</p>
<p>CERNIERA MASCHIO</p> 	<p>CMIS... CMKS...</p>
<p>CERNIERA FEMMINA CON PERNO</p> 	<p>CFIS... CFKS...</p>

\varnothing	A1	B1	C	D1
32	75	22	10	26
40	78	25	12	28
50	85	27	12	32
63	93	32	16	40
80	102	36	16	50
100	118	41	20	60

fissaggi per cilindri compatti ISO

fixing elements for ISO compact cylinders



OBSOLETO
OBSOLETE

Per altre informazioni vedi le pagine 538-544 (fissaggi per cilindri ISO 15552)

For more information refer to pages 538-544 (fixing elements for cylinders ISO 15552)

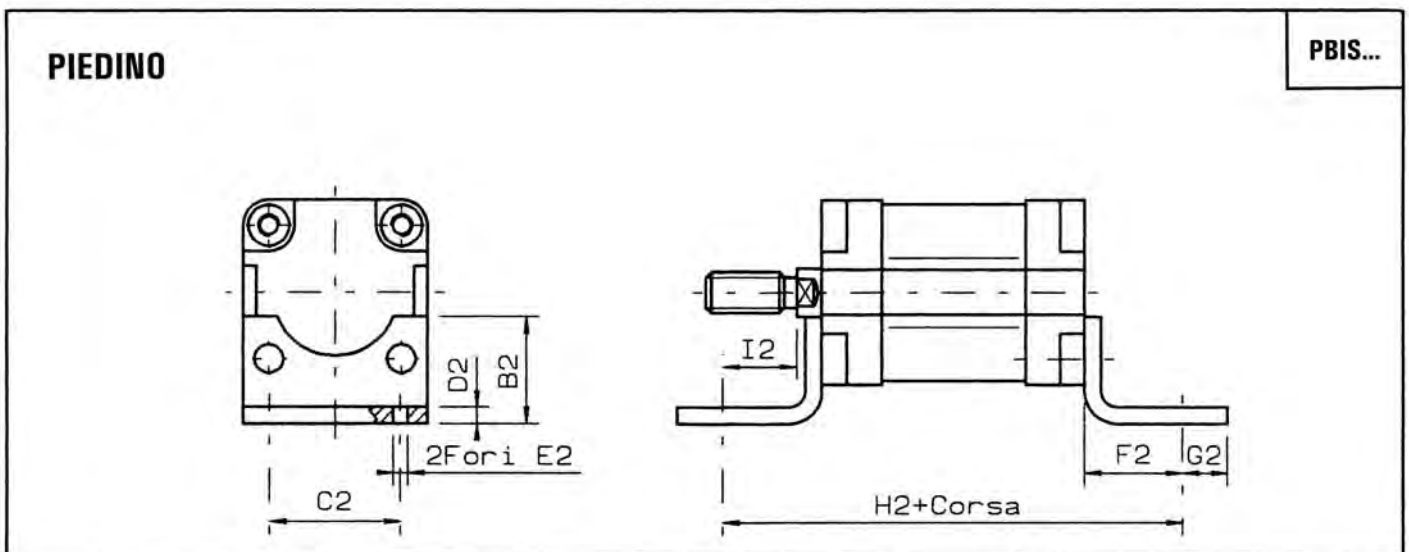
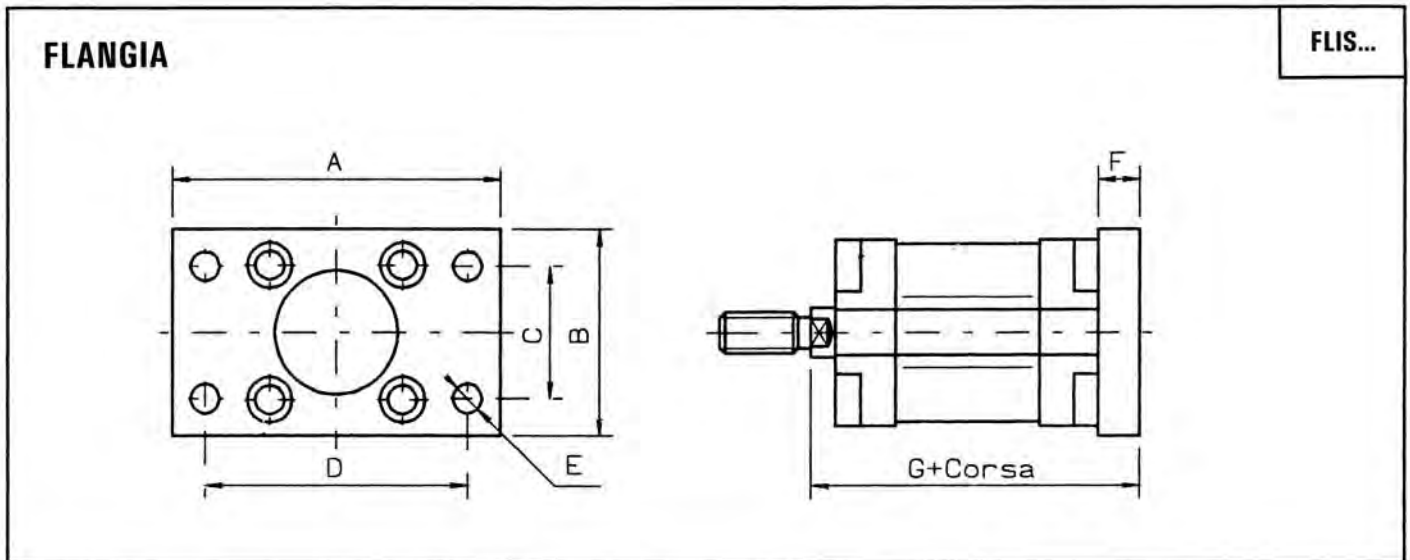

G	F	E	D	C	B	A	∅	B2	C2	D2	E2	F2	G2	H2	I2
63	10	7	64	32	45	80	32	30	32.5	4	7	24	11	94	17
63	10	9	72	36	52	90	40	30	38	4	9	28	8	102	21
70	12	9	90	45	65	110	50	36	46.5	5	9	32	15	114	24
73	12	9	100	50	75	120	63	35	56.5	5	9	32	13	117	24
82	16	12	126	63	95	150	80	47	72	6	12	41	14	138	31
93	16	14	150	75	115	170	100	53	89	6	14	41	16	149	31