

cilindri pressori

clamping cylinders

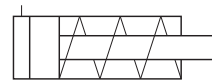

- Cilindri semplice effetto antirotazione, molla anteriore
Single acting front spring cylinders, anti-rotation
- Non magnetici
Non-magnetic
- Ottimi per il serraggio dei pezzi da tagliare su macchine troncatrici per alluminio o legno
Very good cylinders to clamp the pieces in sawing machines for aluminium or wood



modello <i>model</i>	alesaggio interno <i>internal bore</i>	corsa <i>stroke</i>	esecuzione <i>execution</i>
17.066.0	25 mm	8 mm	con tampone di spinta <i>[with pushing pad]</i>
17.062.0	25 mm	75 mm	con tampone di spinta <i>[with pushing pad]</i>
17.067.0	25 mm	110 mm	con tampone di spinta <i>[with pushing pad]</i>
17.068.0	35 mm	8 mm	con tampone di spinta <i>[with pushing pad]</i>
17.060.0	35 mm	75 mm	con tampone di spinta <i>[with pushing pad]</i>
17.061.0	35 mm	110 mm	con tampone di spinta <i>[with pushing pad]</i>
17.069.0	35 mm	75 mm	con tampone di spinta e testata anteriore filettata <i>[with pushing pad and threaded front end cap]</i>



Materiali

Corpo: alluminio anodizzato

Stelo: AVP zincato

Guarnizioni: NBR e poliuretano

Materials

Body: aluminium (anodize treatment)

Piston-rod: zinc plated AVP steel

Sealings: NBR and polyurethane

RICAMBI - spare parts

tampone per cilindro pressore
pad for clamping cylinder

17.074.0



Pressione di esercizio <i>Working pressure</i>	2 ... 10 bar 0.2 ... 1 MPa
Temperatura di esercizio <i>Temperature range</i>	max +60°C
Alesaggi interni <i>Internal bores</i>	25; 35 mm
Corse <i>Strokes</i>	8; 75; 110 mm
Fluido <i>Fluid</i>	Aria filtrata 50µ con o senza lubrificazione <i>50µ filtered, lubricated or non lubricated air</i>

cilindri pressori

clamping cylinders



alesaggio interno 25 mm; corsa 8 mm e 75 mm
internal bore 25 mm; stroke 8 mm and 75 mm

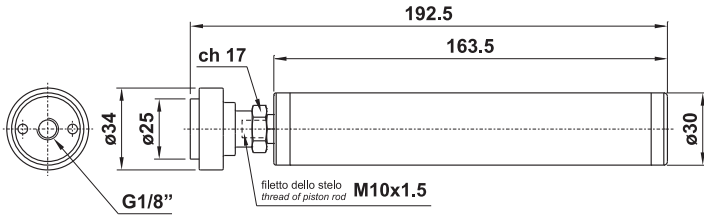

alesaggio interno 25 mm; corsa 110 mm
internal bore 25 mm; stroke 110 mm

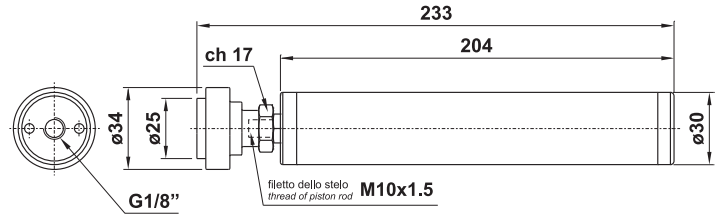

alesaggio interno 35 mm; corsa 8 mm e 75 mm
internal bore 35 mm; stroke 8 mm and 75 mm

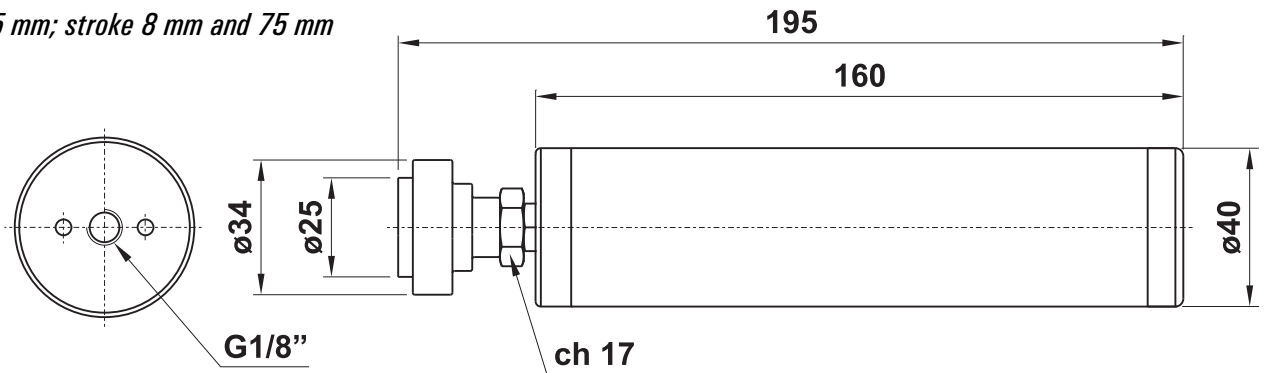

alesaggio interno 35 mm; corsa 110 mm
internal bore 35 mm; stroke 110 mm

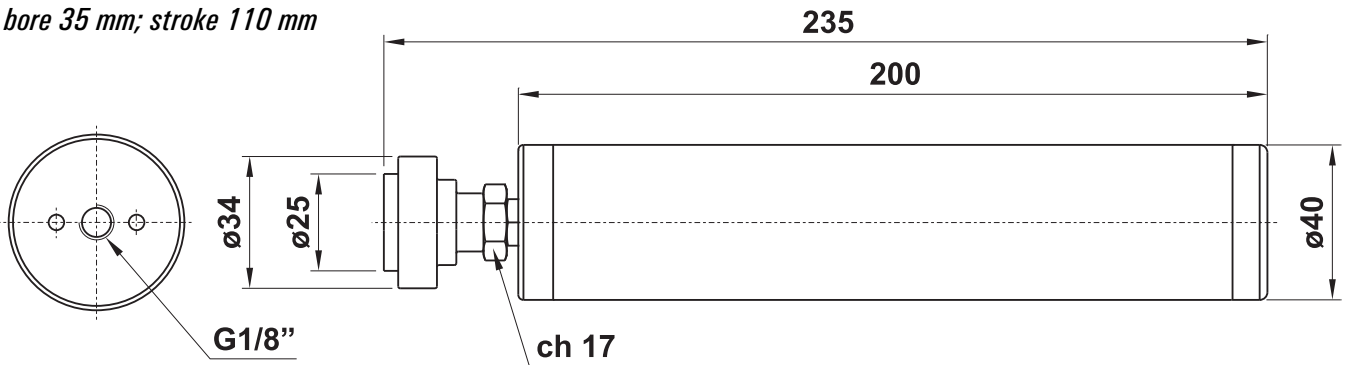

alesaggio interno 35 mm; corsa 75 mm; testata filettata
internal bore 35 mm; stroke 75 mm; threaded front end cup

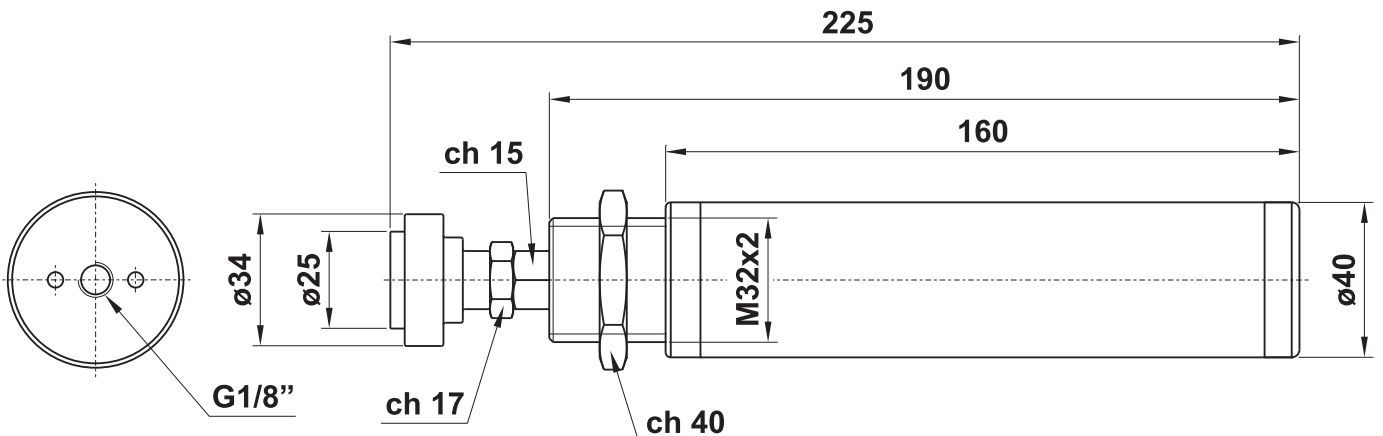

cilindri pressori con valvola di blocco integrata

clamping cylinders with integrated pneumatically piloted stop valve



- Cilindri semplice effetto antirotazione, molla anteriore
Single acting front spring cylinders, anti-rotation
- Non magnetici
Non-magnetic
- Ottimi per il serraggio dei pezzi da tagliare su macchine troncatrici per alluminio o legno
Very good cylinders to clamp the pieces in sawing machines for aluminium or wood
- Valvola di blocco a comando pneumatico G1/8" integrata (per maggiori informazioni vedi pag. 384)
Integrated pneumatically piloted G1/8" stop valve (for more information refer to page 384)

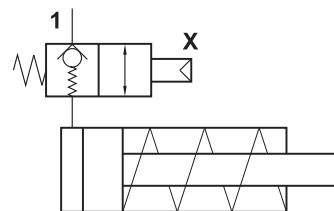

modello <i>model</i>	alesaggio interno <i>internal bore</i>	corsa <i>stroke</i>	esecuzione <i>execution</i>
17.005.4	35 mm	8 mm	con tampone di spinta <i>[with pushing pad]</i>
17.006.4	35 mm	75 mm	con tampone di spinta <i>[with pushing pad]</i>
17.007.4	35 mm	110 mm	con tampone di spinta <i>[with pushing pad]</i>
17.008.4	35 mm	75 mm	con tampone di spinta e testata anteriore filettata <i>[with pushing pad and threaded front end cap]</i>

Materiali

Corpo: alluminio anodizzato

Stelo: AVP zincato

Guarnizioni: NBR e poliuretano

Materials

Body: aluminium (anodize treatment)

Piston-rod: zinc plated AVP steel

Sealings: NBR and polyurethane

Pressione di esercizio <i>Working pressure</i>	2 ... 10 bar 0.2 ... 1 MPa
Temperatura di esercizio <i>Temperature range</i>	max +60°C
Alesaggi interni <i>Internal bores</i>	35 mm
Corse <i>Strokes</i>	8; 75; 110 mm
Fluido <i>Fluid</i>	Aria filtrata 50µ con o senza lubrificazione <i>50µ filtered, lubricated or non lubricated air</i>

cilindri pressori con valvola di blocco integrata

clamping cylinders with integrated pneumatically piloted stop valve



alesaggio interno 35 mm; corsa 8 mm e 75 mm

internal bore 35 mm; stroke 8 mm and 75 mm

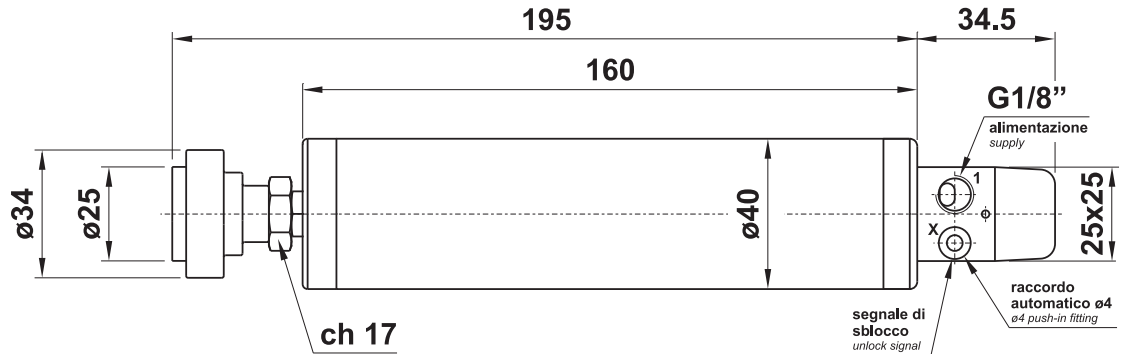

alesaggio interno 35 mm; corsa 110 mm

internal bore 35 mm; stroke 110 mm

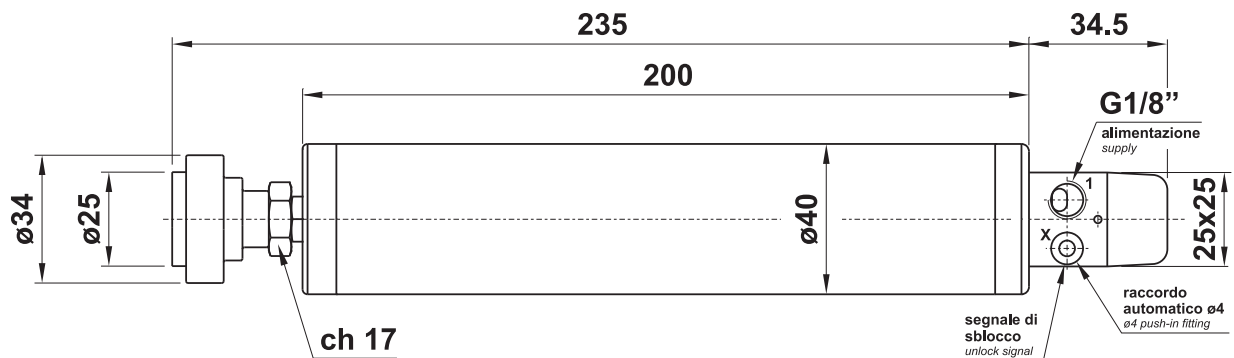

alesaggio interno 35 mm; corsa 75 mm; testata filettata

internal bore 35 mm; stroke 75 mm; threaded front end cup

